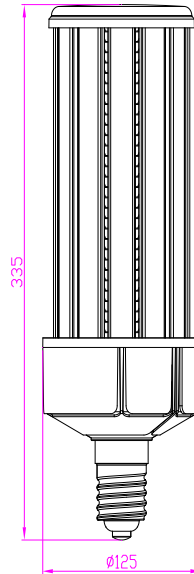

**ITEM#612**

LED KING LIGHTING DISTRIBUTION

E-mail: sales@ledkingtx.com

www.ledkingtx.com

**NAME:** LED Corn Light**P/N:** SNC-CLW-150WB1**Advantage**

- UL、CUL certificate
- E39 lamp base
- Warm / Natural / Cool / Cold white
- 360 degree lighting, high CRI.
- IP64 Waterproof Rating
- Big heat sink, double SUNON fans.
- Can be with clear or frosted cover.
- Internal driver, input voltage AC100-277V.
- New style and high efficient wide-range input.
- Long lifespan and good heat dissipation.
- Direct replacement for Metal Halide, Easy Installation
- Fits many different fixtures to replace traditional lam

**Application**

Widely used in supermarket, warehouse, garage, home, office, hotel, hospital, school, street, garden

etc

PRODUCT SPECIFICATIONS		
Product name	LED Corn Light	
Light Type	Corn Light	
Part No	SNC-CLW-150WB1	
Dimension	Φ125*335 MM	
Technical Characteristic		
Cover	Clear	Frosted
Color temperature	2700-6500K	
CRI	> 80	
Lumen	18700-20200 LM	15700-17200 LM
Lumen Efficacy	125-135 LM/W	105-115 LM/W
Input Power	150 W	
Viewing Angle	360 degree	
Input Voltage	AC100-277V 50/60Hz	
PFC	>0.9	
Equivalent	400W MHL/HPS/HID	
Waterproof Rating	IP64	
MATERIALS		
LED Brand	EPISTAR	
LED Type	SMD2835	
LED QTY	1064 PCS	
Housing	PC+AL	
Housing color	White+Grey	
OTHERS		
Operating Temperature	-20°C TO 45°C	
Operating Humidity	20%-70% RH	
Storage Temperature	-30°C TO 80°C	
Storage Humidity	10%-75% RH	
Application	Indoor/Outdoor	
Safety Certification	UL、CUL	
Warranty Time	5 Years	

Remark: The testing data comes directly from the product test.

DATA OF LAMP		PHOTOMETRIC DATA <span style="float: right;">Eff: 136.31 lm/W</span>			
MODEL		I <sub>max</sub> (cd)	2134	S/MH (C0/180)	3.65
NOMINAL POWER (W)	150	LOR (%)	100.0	S/MH (C90/270)	3.59
RATED VOLTAGE (V)	120	TOTAL FLUX (lm)	20121	η UP, DN (C0-180)	22.8, 26.9
NOMINAL FLUX (lm)	20120.9	CIE CLASS	DIFFUSE	η UP, DN (C180-360)	23.7, 26.6
LAMPS INSIDE	1	η up (%)	46.6	CIBSE SHR NOM	2.00
TEST VOLTAGE (V)	120	η down (%)	53.4	CIBSE SHR MAX	0.00

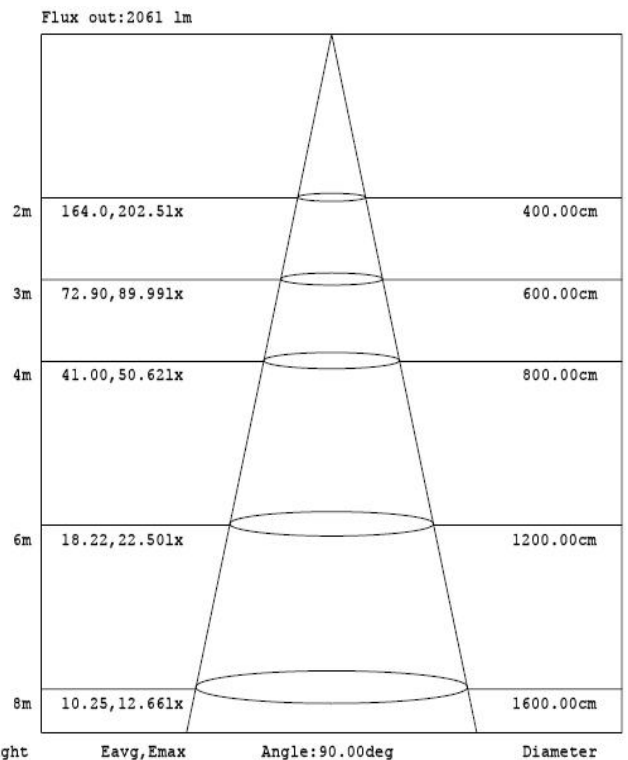
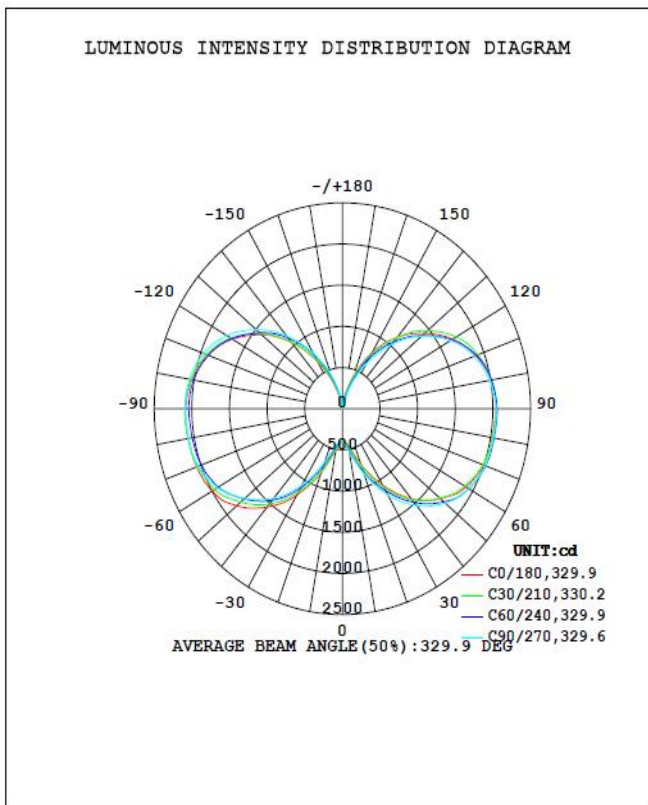

Note: The Curves indicate the illuminated area and the average illumination when the luminaire is at different distance.

## Package

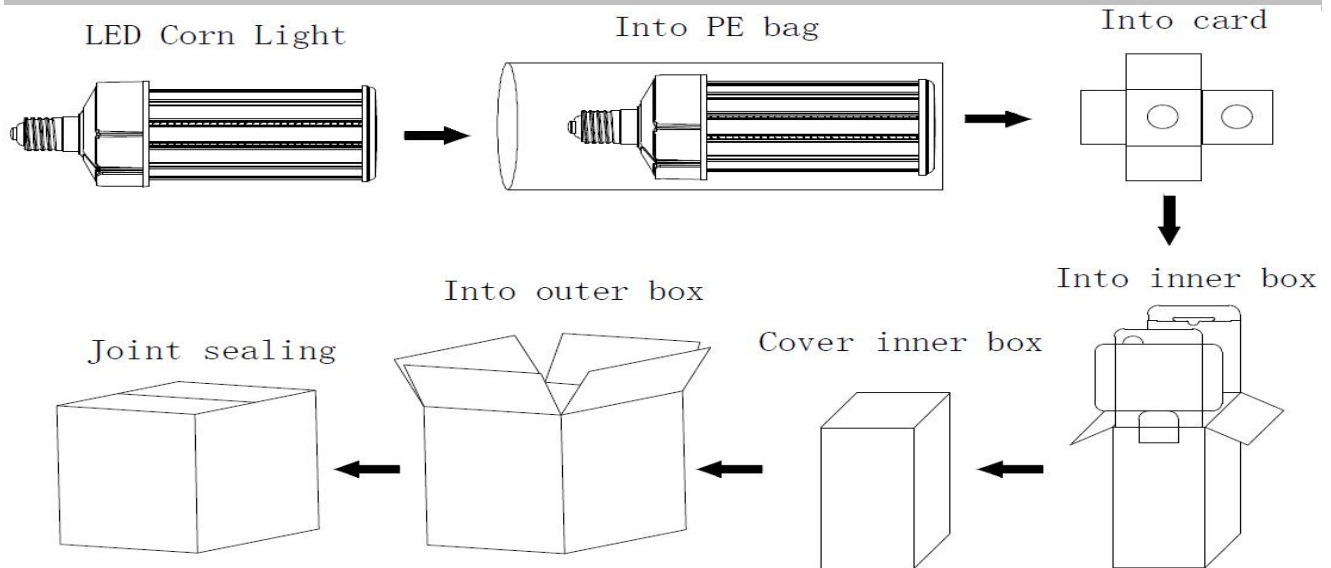

	Size	Qty/ Carton	Net Weight/ Carton	Gross Weight/ Carton
Inner box	130*130*360 MM	1 PC	1.34 KG	1.54 KG
Outer box	405*275*380 MM	6 PCS	8.0 KG	10.2 KG

## Notice For User

- Please turn off power before install or change assembly parts.
- The input voltage and lamps should be matched, after connecting the power line, please make sure the wiring section is insulated.
- Make sure to remove or bypass the ballast in the fixtures before install the lamps.
- Suitable for damp locations. Do not use with dimmers.
- Suitable for use in enclosed luminaires, min. lamp compartment dimensions: 470\*270\*270MM.
- No-professionals, must not install and disassemble the lamps.

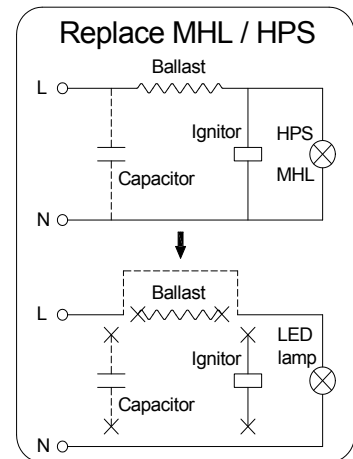
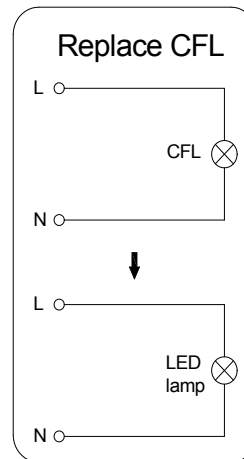

## Trouble Shootings

Troubles	Check points
Flickering of the lamps	Turn off the power and turn on again in 3 minutes. If same phenomena occur, then call agencies
Out of working	Please check the connection